

CMT

Top loading cartoning system

The CMT is a flexibly configurable system for erecting, filling and closing open or closed folding cartons. It is designed for high performance requirements. In the product infeed, outputs of up to 1,000 products per minute are possible; maximum output is up to 200 cartons per minute (depending, among other factors, on product, pack style and format). The system is suitable for applications where items are precisely pre-grouped and inserted into display folding cartons, particularly in the confectionery and food industries. The cartons are erected from flat blanks and filled in the desired pack formation with products that are either stackable or non-stackable. Thanks to its modular design, the CMT supports various layout options.

Functional and design features

- > Designed for high overall equipment effectiveness (OEE)
- > Quick and repeatable format changeover
- > Vertical start-up after a format changeover
- > Settings can be saved and recalled, making them largely reproducible
- > Designed for reliable operation, high line availability and efficient processes
- > Small footprint despite high-performance applications
- > Flexible implementation of different packaging designs/pack styles
- > Smart Infeed: high-performance infeed for stable product transfer
- > Largely tool-free format and belt changeovers
- > Good maintenance and cleaning accessibility of the working areas
- > Maintenance-optimized concept to support enable cleaning and service intervals

> Packaging your ideas...



Loesch Verpackungstechnik GmbH + Co. KG · www.loeschpack.com
Industriestrasse 1 · 96146 Altendorf/Germany · sales@loeschpack.com

Complete packaging lines
Feeding, Distribution, Buffering
HFFS-flow wrapping systems
Fold wrapping systems
Cartoning systems
Customised machines

Chocolate
Chewing gum & Confectionery
Cookies & wafers
Cereal bars
Pharma
Food & Non-Food

LoeschPack
PIEPENBROCK GROUP



LoeschPack easyMI for simple and user-friendly operation

Discharge rate: up to 200 cartons per minute



Infeed rate: up to 1,000 products per minute

Fast and easy format changeovers, vertical start-up

Several different layout variants



Carton variants: the presentation direction is defined by the blank layout. Single- or multi-layer, single- or multi-row. This determines the orientation of the products in the carton.

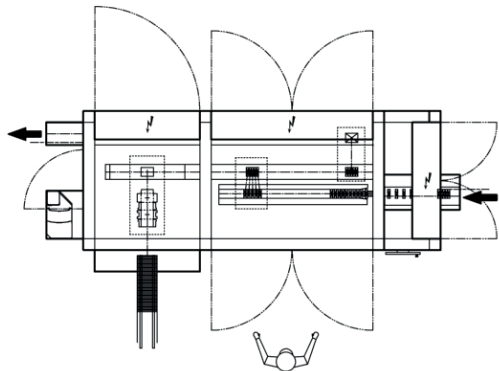

Variant 1
Inline high-performance infeed

Depending on the type of primary packaging, the products are fed into the cartoner's racetrack inline, either rotated or unrotated.

Single- or twin-lane inline infeed is possible for products lying flat or standing on edge

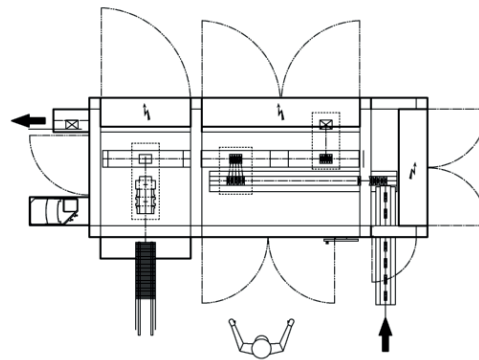

Variant 2
90° Infeed

Single- or twin-lane infeed: one racetrack per infeed.

Infeed directions can be combined as required.

Single- or twin-lane 90° infeed is possible for products lying flat or standing on edge

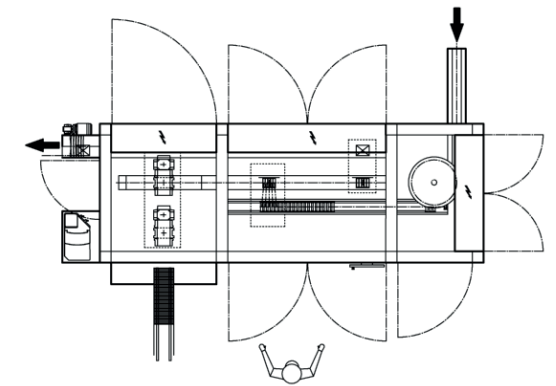

Variant 3
Transformation wheel

The Transformation Wheel enables significantly higher speeds for the 90° infeed.

